

KOMATSU 830E 2-4/930E 2-4
DUMP TRUCK

BreatheSafe

Parts and Service Manual

Kit Number: **710053**

Controlled Document: M0257/25

Intelligent Air Quality Monitoring and Management Solutions | [breathe-safe.com](https://www.breathe-safe.com)

Contents

Components	1
WARNING	2
Particulate Behaviour	2
Critical Parts.....	3
Suggested Schedule Servicing*.....	3
Maintenance Schedule	4
Maintenance Check List.....	4
Operator’s Checklist.....	5
Alerts	5
Kit Number: 700941, 700674.....	7
Wiring Diagram – InPress Controller.....	8
Wiring Diagram – OnGuard Controller.....	9
Cabin Sealing Efficiency Test Procedure	10
Hand-Held Differential Pressure Monitor (HHDPM) Leakage Test.....	11
General Guide to Cabin Sealing, Testing and Commissioning	12
InPress Troubleshooting Guide.....	13
Commissioning Guides:.....	14
InPress:	14
Controller Manuals:	14
InPress Manual	14
OnGuard Manual	14
Services and Warranty:.....	14
Commission Your System Here.....	14
Audit Your System Here.....	14
BreatheSafe Warranty	14

Components



HEPA Variable Speed
Pressuriser



HEPA Return Air Filter



Custom Install Kit



Air Quality Controller

WARNING

The pressurisation system described in this manual has the following areas which may be dangerous if not treated with great care.

Qualified staff must wear the correct personal protective equipment when cleaning and servicing this unit due to dust and fibres which may be caught by the stages of air filtration during normal unit operation.

The electrical power system is supplied by 12V DC or 24V DC, and no work should be carried out on the pressuriser system without the correct safe work procedures and electrical safety measures being taken, and all relevant circuit breakers opened to isolate the circuit.

The air filtration system may have several types of high-speed rotating equipment installed with very sharp edges. Ensure all safety guards are in place while the system is running.

Please be aware that HEPA filters cannot be cleaned and must be replaced at the end of their lifecycle or if the filter media has been damaged.



Particulate Behaviour

This is the length of time it takes for a particle to drop from a height of 1.5m in STILL air.

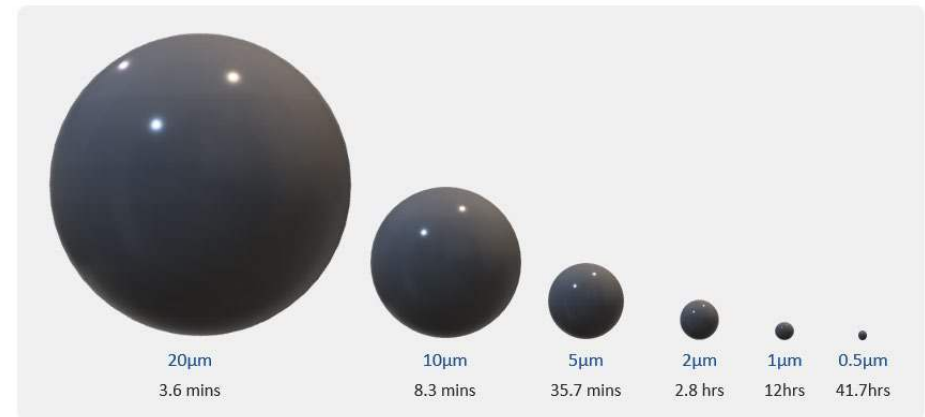

Warehouses and workshops do not have still air, so hazardous airborne particulates may remain in air for longer, increasing chance for workers to breathe in dust. Ensure PPE is worn when installing this system.

This air quality system is designed to protect operators from harmful airborne contaminants. Keep the doors and windows closed at all times.

Critical Parts

No.	Part No.	Qty	Description	Service Int.
1	500000	1	Fresh Air HEPA H14 Filter	>80% fan capacity
2	5000--	1	HEPA Return Air Filter	500* hours
3	200002	1	Brushless Blower Motor	15,000 hours
4	200000	1	HEPA H14 Pressuriser	-
5	200027	1	InPress Controller	25,000* hours
6	200510	1	OnGuard Controller	25,000* hours
7	200361	1	OnGuard Main Unit	-
8	500069	1	Activated Carbon Filter	500* hours

*Filter service hours are subject to cab sealing efficiency, site conditions and correct system use.

Suggested Schedule Servicing*

Fan Capacity Indicator

The filter is serviceable if the motor capacity is between 10% & 80%. We recommend that the filter is changed if the capacity is at or over 80%.

*Site dependent.

InPress

8:30 22/04/24 25%

Cabin Pressure 50Pa

CO2 Level 200PPM

Temperature 20°C

OnGuard (Touch Screen)

2024-06-11 12:30:43 ✓

Pressure: +50 Pa

Motor: 28 %

CO₂: 631 ppm

PM₁₀: 2.1 µg/m³

TWA PM₁₀: 1.5 µg/m³

Maintenance Schedule

The following tables show our suggested maintenance schedule for all units. Please note that site conditions may alter this. Excludes high corrosion environments.

Data download is required to claim the 3-year warranty on Brushless Blower Motor.

Inspect every **500 hours** and replace when filter is full*

Component / System	Action Required
Turbo pre-cleaner	Check operation of the turbo pre-cleaner.
Pressuriser	Ensure motor is operational.
HEPA primary filter	Check motor capacity on controller display. Replace HEPA filter when 80% or greater. Vacuum out housing before replacing the filter.
HEPA return air filter	Vacuum inside cabin floor before replacing filter.
Metalwork, mounts and cabin seals	Check door and window seals, bolts, screws, and all mounts are in serviceable condition.

15,000 hours / 36 months*

Component / System	Action Required
Pressuriser	Replace brushless motor.

*Inspection hours are subject to cab sealing efficiency, site conditions and correct system use.

Maintenance Check List

Task	Check
Check all Deutsch plugs are securely connected	
Visually inspect the cabin for any damage to doors, windows and seals	
Check pressuriser for external damages	
Check pressuriser filter for damage & filter is locked in position	
Check pressuriser ductwork is in good condition	
Check duct clamps are tight	
Check mounting and support bracket bolts are fastened	
Check mounting and support bracket for signs of damage	
Check HEPA outlet panel filter condition & correct airflow direction	
Check HEPA outlet panel filter frame condition	
Check HEPA outlet panel filter grille is secured with all knobs/bolts in place to effectively seal against filter	
Check monitor activates by ignition	
Check monitor screen is legible	
Date / time correct	
Confirm pressure is 0 Pascal with the door open (system on)	
Check low pressure alarm activates (audible and visual) with door open	
Initiate max pressure test with cabin doors closed final result	
Max Pressure must be 250Pa or greater with new filters. <250Pa requires cabin seal improvements	
Set Point <u> 50 </u> Actual Pressure <u> </u> Motor %	
Fill out / update commissioning sticker	

Operator's Checklist

Pre-Start	
1	Visually inspect the pressuriser, ducting, mounting brackets, and return air filter assembly.
2	Visually inspect the cabin for any damage to doors, windows and seals.
3	Please remove debris from shoes and clothes before entering the cabin.
4	Ensure doors and windows are closed correctly.
5	Start engine and turn HVAC blower to mid speed or greater.
6	After automatic pressure test, the BreatheSafe display will show 50 Pascals or pre-set value.

The system is working correctly when the display is showing 50 Pascals or pre-set value. No further action required.

Normal Operating Condition

BreatheSafe recommends OEM air conditioning fan is set at mid-speed or greater to circulate air around the breathing zone and minimise CO₂.

Acceptable operating range for BreatheSafe fan is 10-80%.

InPress

8:30	22/04/24	25%
Cabin Pressure	50Pa	
CO2 Level	200PPM	
Temperature	20°C	

OnGuard (Touch Screen)

2024-06-11 12:30:43		
Pressure:	+50 Pa	
Motor:	28%	
CO ₂ :	631 ppm	
PM ₁₀ :	2.1 µg/m ³	
TWA PM ₁₀ :	1.5 µg/m ³	

Alerts

Types of Alerts: InPress

Fixed Fan Start Delay	Allows the operator to carry out pre-start checks, limiting at 30% fan speed. Press red text to disable the alert.
CO ₂ Level Alert (If equipped with Sensor Pod)	Ensure that the air conditioning fan is set at mid speed or greater to circulate air and minimise CO ₂ .
Low Pressure Alarm	Cabin is not maintaining positive pressure, check that the doors and windows are closed correctly. Refer to maintenance department to check filters and cabin sealing.
Check Filter	Reminder to inspect or replace filter. Service hour meter requires reset. Once replaced, refer to the maintenance department.
Low Pressure – Service Mode	Cabin will not gain pressure and limits the pressuriser capacity to 30%. Ensure all doors and windows are CLOSED correctly (no cabin pressure leaks) and refer to the maintenance department.

Types of Warnings and Alerts: OnGuard

Max Capacity Pressure is low, Check Filter	Motor is operating at maximum speed and cannot reach target pressure. Check cabin sealing, ducting from enclosure to pressuriser, and filter condition. Replace filter if issue persists.
Pressure Warning Close Doors and Windows	Pressure is below warning threshold (default 5 Pa), system has reduced fan motor to safety speed. Check that the doors and windows are closed correctly.
High CO ₂ Level	First alarm threshold for CO ₂ level reached (default 1000 ppm). Ensure OEM air conditioning fan is set at mid-speed or greater to circulate air around the breathing zone and minimise CO ₂ .
No Air Pressure	Pressure warning has persisted, and system has escalated warning to an alert. Check cabin sealing, outside pressure tube is connected to unit and not kinked or blocked, pressuriser is powered and running, and ducting from pressuriser to cabin is connected and undamaged.
Very High CO ₂ Level	Critical alarm threshold for CO ₂ level reached. System will temporarily increase fresh air intake to reduce CO ₂ concentration. Ensure OEM air conditioning fan is set at mid-speed or greater to circulate air around the breathing zone and minimise CO ₂ .
High Dust Level	High dust load detected inside the cabin. System will temporarily flush enclosure with filtered air. Close doors and windows. Check filter is installed correctly, and ducting is not damaged.

Item No.	Qty.	Description	Part No.
1	1	Pre-cleaner Hood & Rotor Assy	200004
7	1	Brushless VSD Motor & TL Fan Blade (12/24V)	200002 / 3
11	1	HEPA H14 Filter	500000

Detail	Description
Part Number	200000
Filter Media (EN1822)	HEPA H14
Length	500.98 mm (19.7")
Diameter	264 mm (10.3")
Outlet Diameter	76.3 mm (3")
Weight	5 kg (11 lb)
Typical Input Voltage	24 VDC
Operating Voltage	22 - 30 VDC
Maximum Current Draw @ 24VDC	11 A
Typical Current Draw	1 - 10 A
Volumetric Airflow Rate	0 - 300 m3/hr
Maximum Pressure	> 1000 Pa
Filter Efficiency @ 0.3µm	> 99.995%
Operating Temperature	-40°C to +85°C (-40°F to +185°F)
Motor	Brushless DC, Variable Speed, IP66 Rated with Soft-Start
Motor Protection Features	Over-Voltage, Under-Voltage, Over-Current, Locked Rotor, Over-Temperature



ISO 23875 Compliant.

Handle with care. Do **NOT** touch filter media.
HEPA filters cannot be cleaned.

HEPA H14 Glass Fibre Filter
 Test Method: EN1822
 Efficiency: 99.995% @ 0.3 Microns

Filter Information

PN: 500000

US: +1 800 359 1704 | AU: +61 7 3276 7833
 sales@breathe-safe.com | breathe-safe.com

KOMATSU 830E 2-4 / 930E 2-4 DUMP TRUCK

BreatheSafe

Kit Number: 710053

Item No.	Rev	Description	Qty	Category
1	0	High Pressure Unit Module	1	Module
2	0	Fresh Air Module	1	Module
3	0	Monitor Mount Module	1	Module
4	0	Pipework Module	1	Module
5	0	Sealing Module	1	Module
6	0	Return Air Module	1	Module
7	0	Misc Module	1	Module

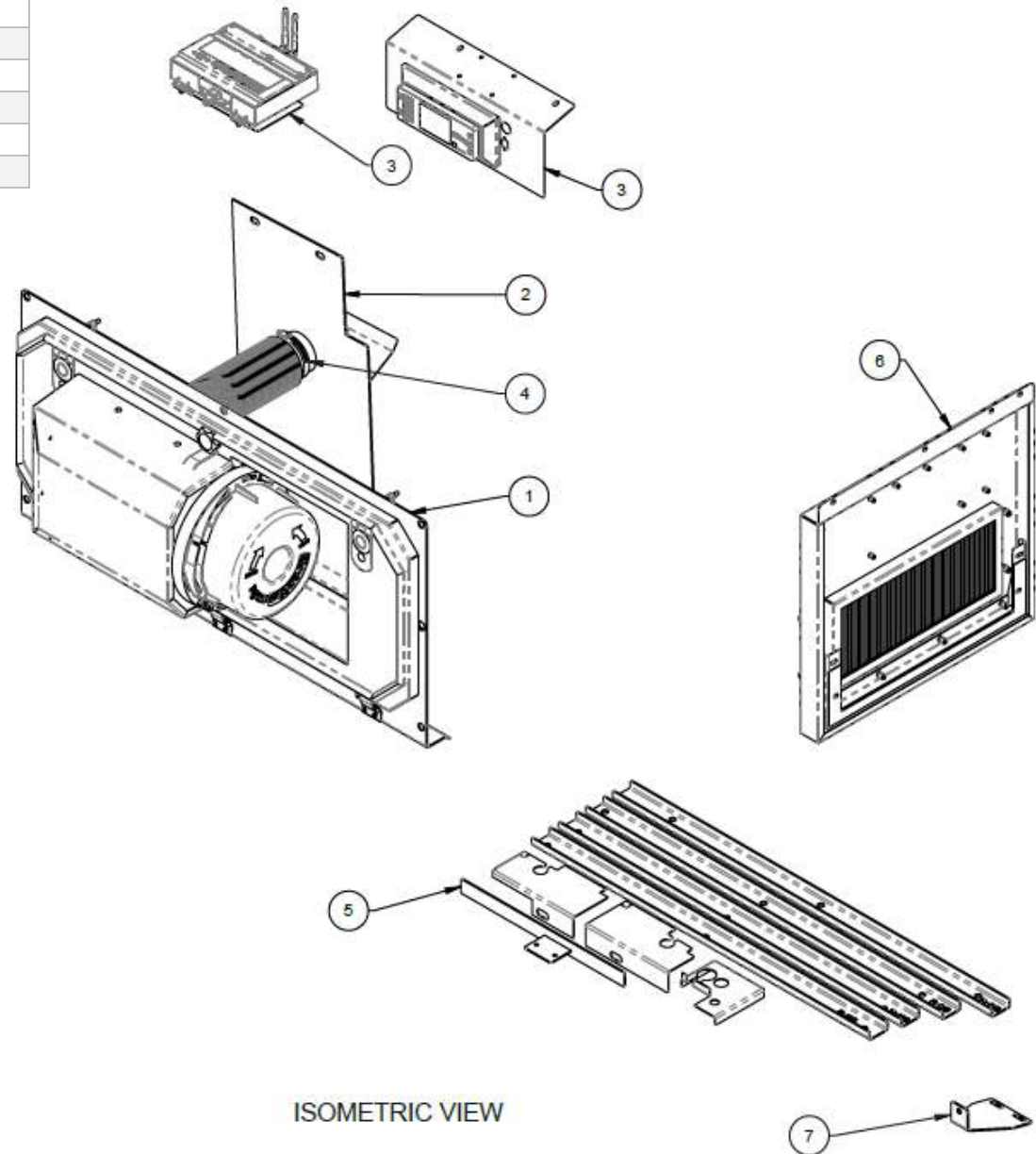

Wiring Diagram – InPress Controller

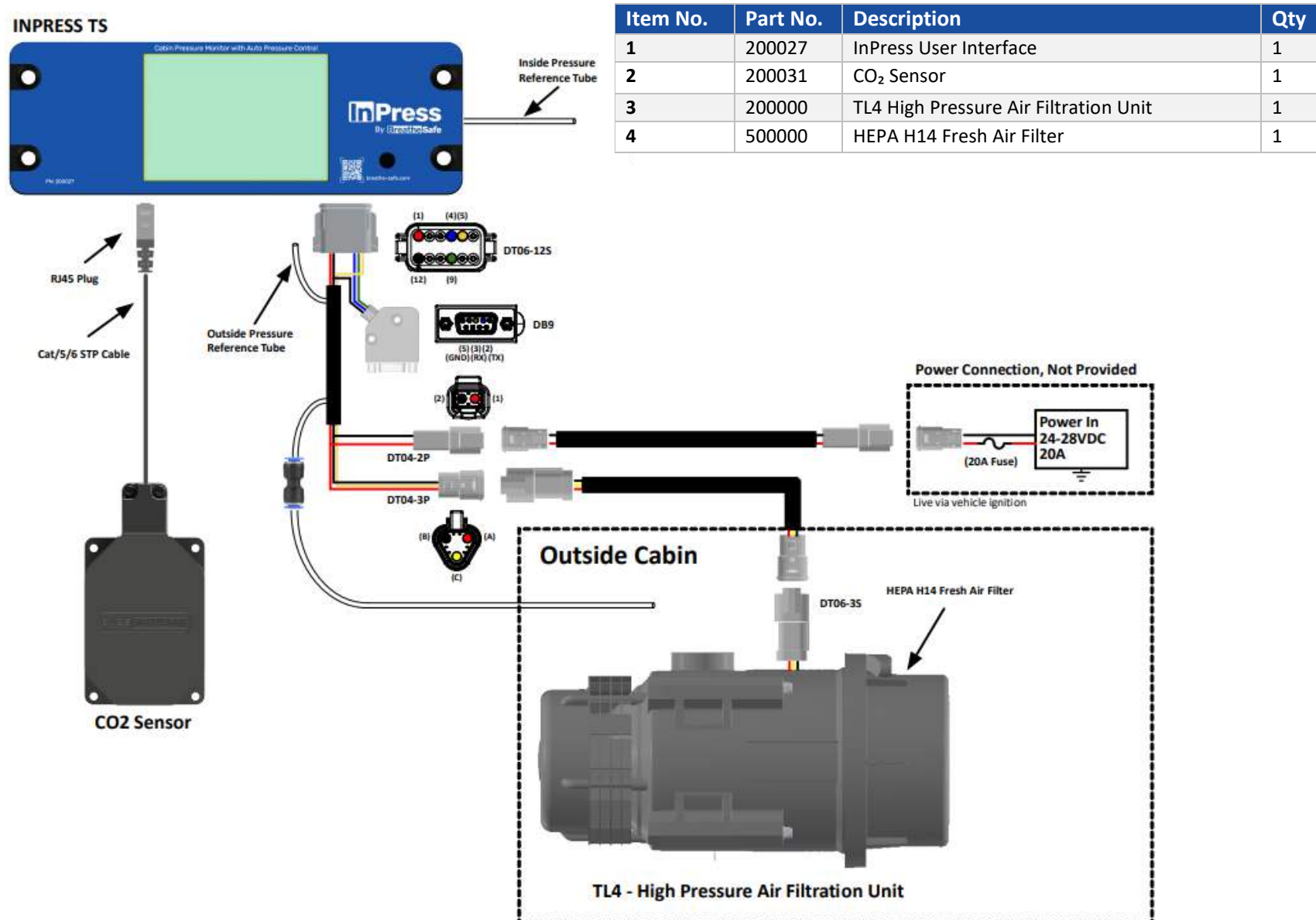

Wiring Diagram – OnGuard Controller

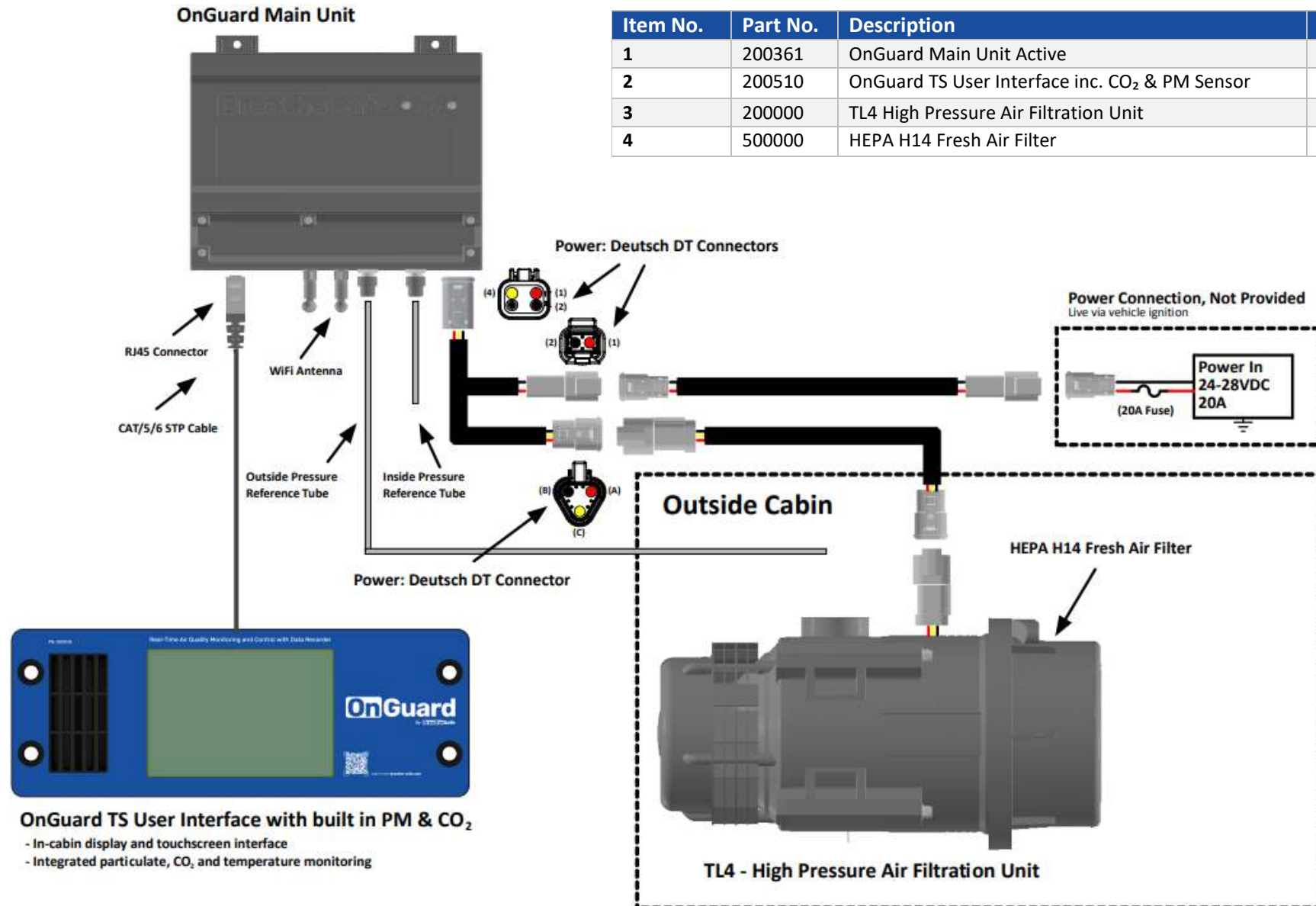

Item No.	Part No.	Description	Qty
1	200361	OnGuard Main Unit Active	1
2	200510	OnGuard TS User Interface inc. CO ₂ & PM Sensor	1
3	200000	TL4 High Pressure Air Filtration Unit	1
4	500000	HEPA H14 Fresh Air Filter	1

Cabin Sealing Efficiency Test Procedure

1	New replacement filter is required to perform this check. Start engine (pressuriser ON) and ensure all windows & door(s) are CLOSED correctly (no cabin pressure leaks).
5	Pressure target is 250 Pa or greater with a new filter. Less than 250 Pa requires cabin sealing improvements.

InPress (Touch Screen)

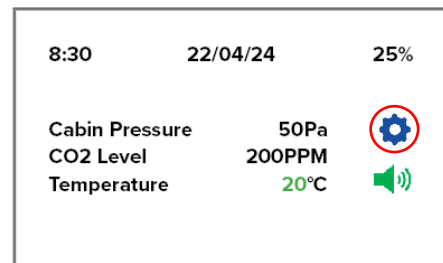

2. Press the settings cog.

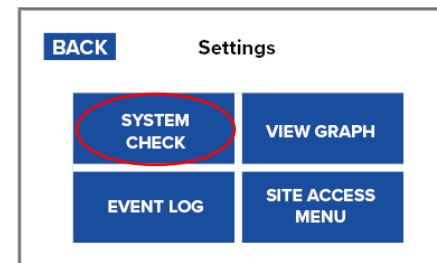

3. Press 'SYSTEM CHECK SET MAX' button.

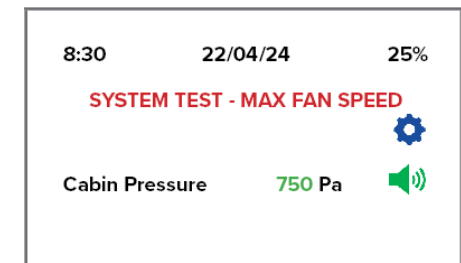

4. Record results. Repeat steps 1 & 2 to finish test.

OnGuard (Touch Screen)

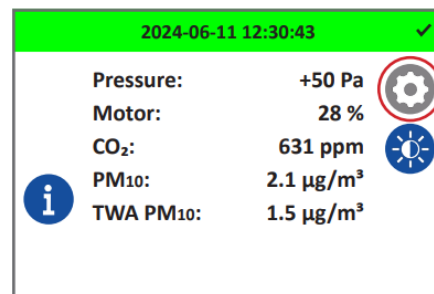

2. Press the settings cog.

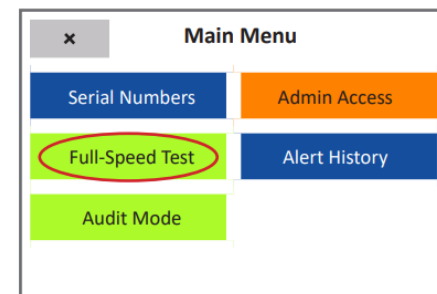

3. Press 'Full-Speed Test' button.

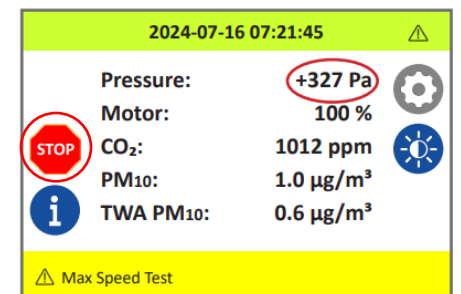

4. Record results. Press 'STOP' to finish test.

Hand-Held Differential Pressure Monitor (HHDPM) Leakage Test

Test enclosure for air leakage using the HHDPM.

Cabin Pressure: Sensor outside the cabin

This leakage test is designed to assist with the cabin sealing process. The monitor will provide feedback on cabin pressure while sealing from outside.

1. With the door open, turn on the HHDPM and observe the pressure reading. Confirm it is reading zero.
2. Connect the pressure reference tube to 'Positive' (top port) place the other end of the tube on the operator seat, away from HVAC vents and any other direct airflow.
3. Activated machine ignition system to energise the pressuriser – the HVAC system remains OFF for pressure testing.
4. Close the door, make sure the tube isn't kinked.
5. Observe the pressure reading and allow it to stabilise. The handheld differential pressure monitor & fixed cabin pressure monitor should read within 5 Pa of each other.
6. Feel around the enclosure for any pressure leaks. Seal enclosure where leaks are present and monitor pressure changes.

Typical Seal Locations:

- Lower pillar openings
- Upper pillar openings where necessary
- Cabin frame
- Floor plates either internal or external – foam tape etc.
- Door seals
- Window seals
- Exterior access panels
- Hydraulic hose entrance points

Part Number: 200142

1. Positive Pressure Port
2. Ambient Pressure Port
3. Charging LED
4. Charging Port
5. Re-Zero Button
6. Power Button
7. Display

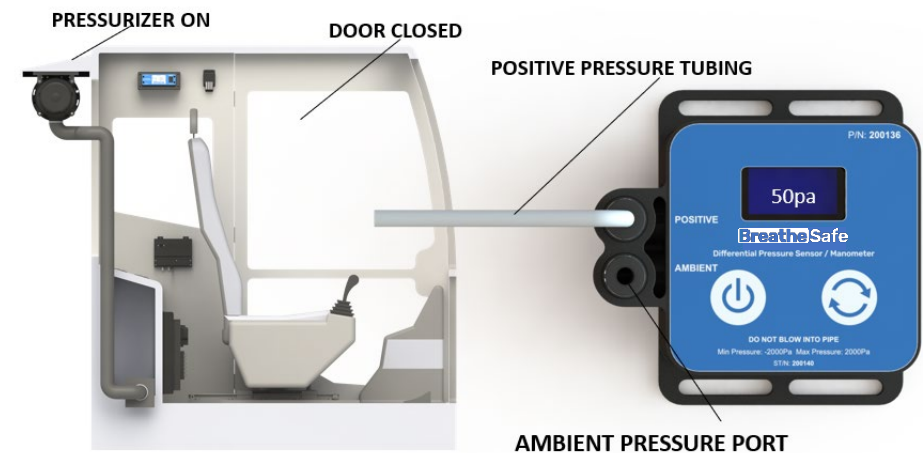

General Guide to Cabin Sealing, Testing and Commissioning

Guide	
1	Clean cabin with a HEPA vacuum.
2	Inspect the cabin and ensure all cover panels are in place, and any cabin pressure leaks are sealed, fit new door seals for used equipment, etc.
3	Sitting inside the cabin with the door open, turn on the ignition to power up the unit.
4	The pressuriser fan should power up to full speed, and the monitor should indicate 0 Pa pressure (Allow ± 2 pascals wind gusts).
5	With the ignition on, close all doors and windows. If the cabin is adequately sealed, the monitor should indicate 50 Pa (Pascals), set pressure or whichever pre-set has been chosen. (If not achieved, check for cabin pressure leaks).
6	Once a cabin pressure of 50 Pa is confirmed, complete the cabin sealing test (page 10).
7	The MAX cabin pressure should be above 250 Pascals related to the efficiency of cabin seals (Please note the minimum result for warranty compliance is 250 pascals tested with a new 500000 HEPA filter). Therefore, a cabin pressure result of 300 - 500 pascals is the ideal result.
8	If the above pressure is not achieved, leave the unit at full speed and investigate external leaks outside the cabin: e.g., A/C outlets, drains, window & door seals, locks & hinges, etc.
9	Locate any air leaks around the cabin and re-test. If silicone sealant or similar is used, allow it to dry before re-testing, as even slamming the door could push the seal back out.
10	Continue the sealing and testing procedure as above until a satisfactory outcome is achieved. Fill out the commissioning sticker and attach photo evidence on cThree of maximum pressure result to register for warranty.

InPress Troubleshooting Guide

Fault	Possible Cause	Solution
*ERR error code	Poor sensor connection	Remove & refit pod connection cable
*Check filter alarm	Service hour timeout	Reset or disable using site access code
Temperature / CO2 error	Sensor not connected	Fit sensor or disable via site access CO2 & or temperature menu
Pressuriser running at full speed/noisy	Filter blocked	Service filter
	Door or window open	Ensure doors & windows securely shut
	Cabin sealing capacity not adequate	Perform pressure test procedure & seal leak points as required
	Sense pipe blocked	Ensure clear & not bent
	Internal sensor damaged	Replace controller **No need to change setpoint
Filter blocking quickly	Defective cabin sealing	Perform pressure test procedure & seal leak points as required
	Pre-cleaner failed	Check operation & replace if necessary
Display blank	Poor power supply	Check mains supply fuse & correct voltage
		Check voltage & 15AMP supply/connections at pin 1 @ monitor
		Check earth continuity at controller pin 12
Displaying low pressure (Low Pressure Alarm) "Low Pressure Service Mode"	Failed controller	Replace monitor
	Fresh air filter blocked	Check filter condition & replace if required
	Door or window open	Ensure doors & windows securely shut
	Cabin sealing capacity not adequate	Perform pressure test procedure & rectify cab sealing
Display reading negative pressure	Pressuriser not operating	Ensure correct voltage 12v or 24v to pressuriser motor pin A
		Check 1.6V - 10V present at motor Pin C
		Check 15A Supply fuse
		Check earth continuity Pin B
Display reading negative pressure	Pressure sense tube blocked / incorrectly connected	Disconnect sense pipe at both sides of joiner & ensure clear flow to external cabin, reconnect pipes securely
		Ensure pressure tube fitted correct port A
		**No need to change setpoint
Pressuriser not working	Poor power supply	Check 15A mains fuse & correct voltage
		Ensure adequate wire size & no voltage drop
		Ensure correct voltage 12v or 24v to pressuriser motor pin A
		Check 1.6V - 10V present at motor Pin C
	Poor earth	Check earth continuity @ motor pin B
Motor faulty	Replace TL4M	
Access Codes:	Site Access: 7597	Factory Setup: Contact for support

Commissioning Guides:

InPress: [Commissioning-Guide-InPress.pdf](#)

OnGuard: [Commissioning-Guide-OnGuard-1.pdf](#)

Controller Manuals:

InPress Manual: <https://www.breathe-safe.com.au/inpress-touch-screen-manual/>

OnGuard Manual: <https://www.breathe-safe.com.au/onguard-manual/>

Services and Warranty:

Commission Your System Here: [Commissioning - BreatheSafe](#)
(<https://www.breathe-safe.com.au/commission>)

Audit Your System Here: [Audit Registry](#) (<https://atreg.breathe-safe.com.au/audits>)

BreatheSafe Warranty: [Warranty - BreatheSafe](#) (www.breathe-safe.com.au/warranty/)